

R7 SERIES

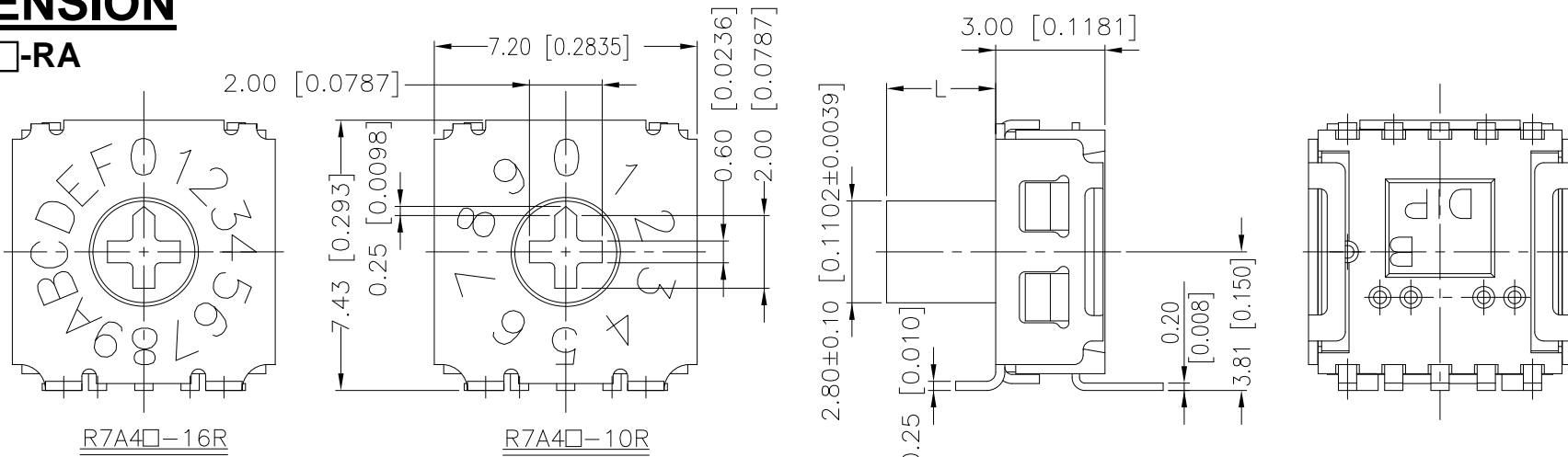

DIMENSION

R7A4□-RA



R7A4□-16R

R7A4□-10R

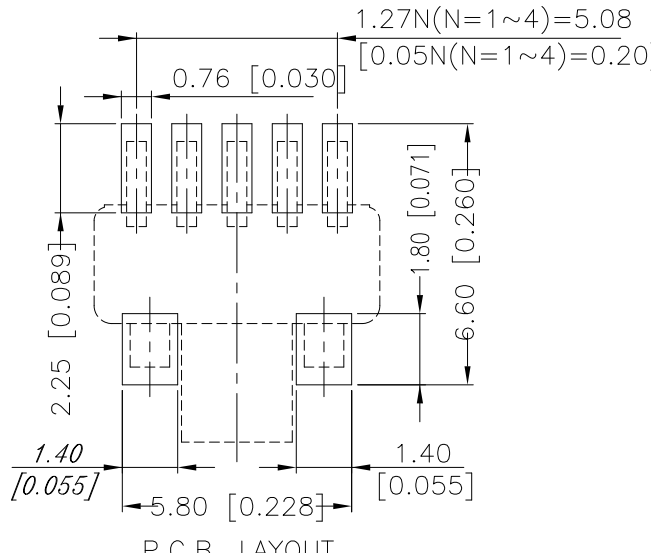
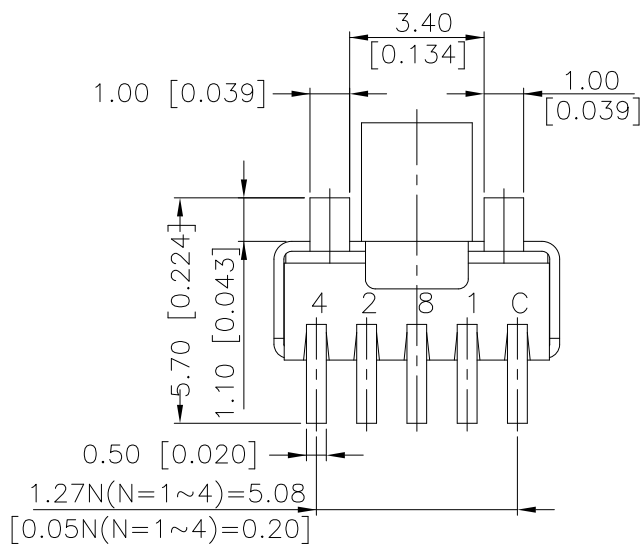

TYPE	POSITION	CODE			
		1	2	4	8
10 STEP	0	●	●	●	●
	1	○	●	●	●
	2	●	○	●	●
	3	○	○	●	●
	4	●	●	○	●
	5	○	●	○	●
	6	●	○	○	●
	7	○	○	○	●
	8	●	●	●	○
	9	○	●	●	○
16 STEP	A	●	○	●	○
	B	○	○	●	○
	C	●	○	○	○
	D	○	●	○	○
	E	●	○	○	○
	F	○	○	○	○

NAME	L
R7A4-10RA-V	0
R7A4-16RA-V	0
R7A4H-10RA-V	3.00 [0.1181]
R7A4H-16RA-V	3.00 [0.1181]

P.C.B. LAYOUT

CIRCUIT CHART

General Tolerance : ±0.2mm

R7H3□-RA

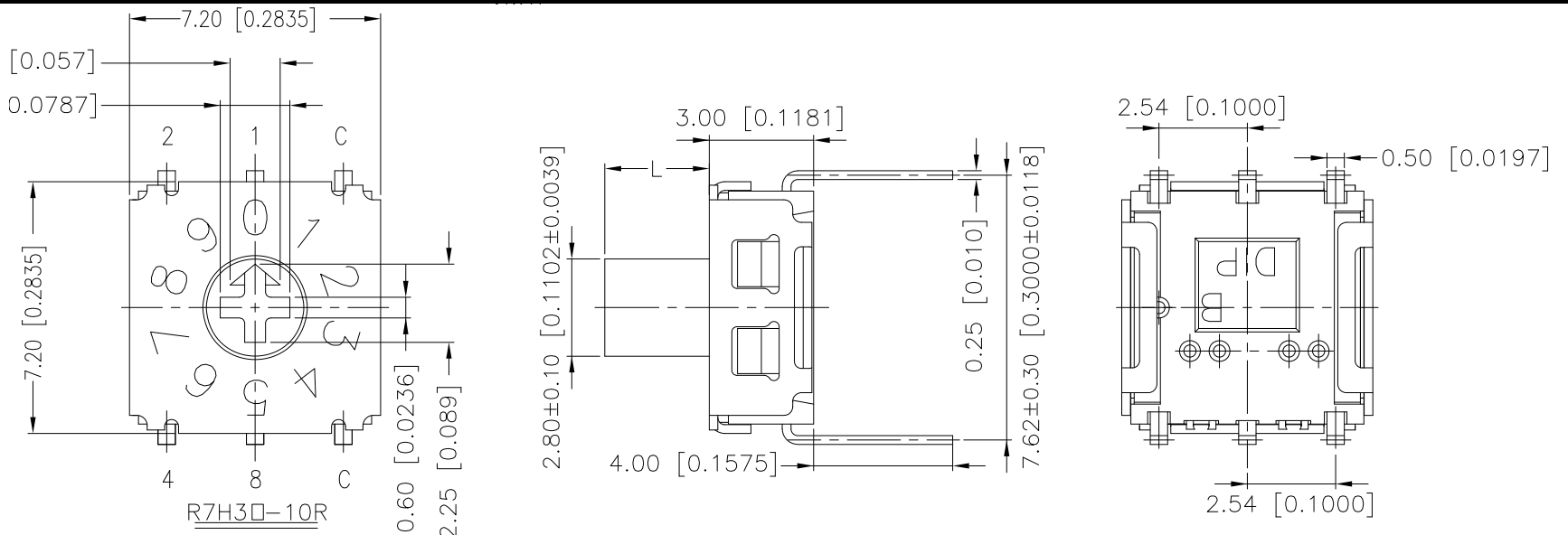

R7H3□-10R

R7H3□-16R

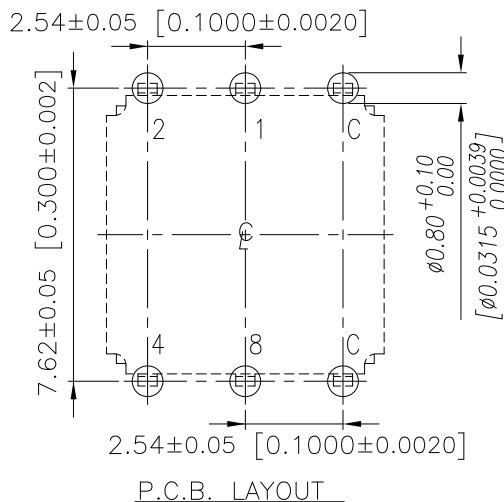

P.C.B. LAYOUT

TYPE	POSITION	CODE			
		1	2	4	8
10 STEP	0	●	●	●	●
	1	○	●	●	●
	2	●	○	●	●
	3	○	○	●	●
	4	●	●	○	●
	5	○	●	○	●
	6	●	○	○	●
	7	○	○	○	●
	8	●	●	●	○
	9	○	●	●	○
16 STEP	A	●	○	●	○
	B	○	○	●	○
	C	●	○	○	○
	D	○	●	○	○
	E	●	○	○	○
	F	○	○	○	○

CIRCUIT CHART

NAME	L
R7H3-10RA-V	0
R7H3-16RA-V	0
R7H3H-10RA-V	3.00 [0.1181]
R7H3H-16RA-V	3.00 [0.1181]

General Tolerance : ±0.2mm

R7M3-RA

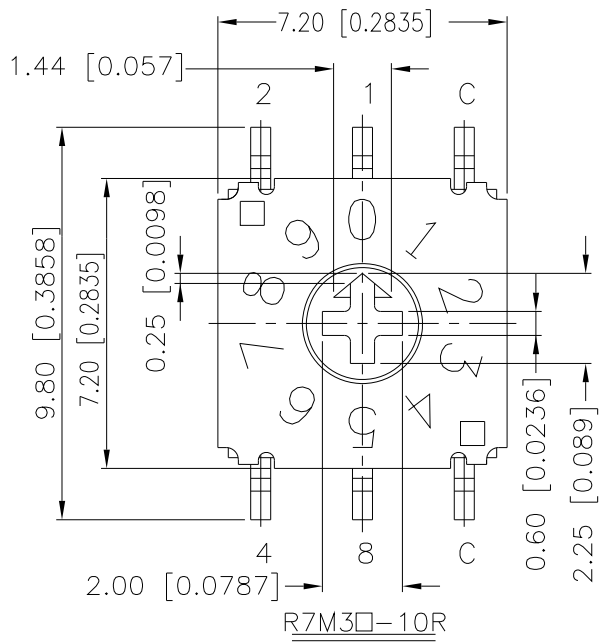

R7M3□-10R

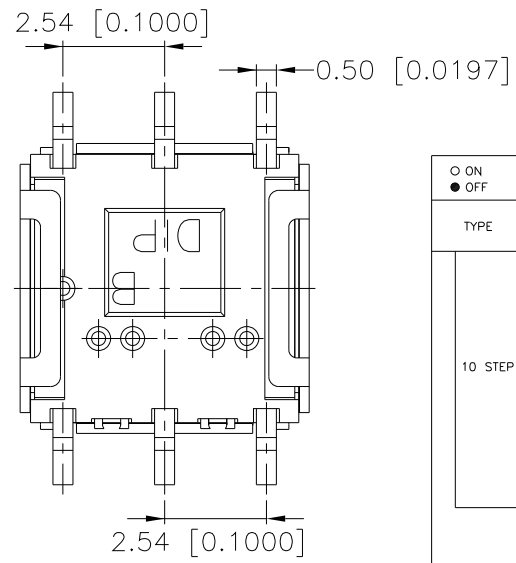
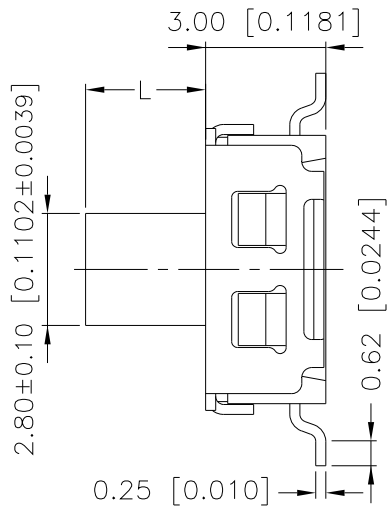

TYPE	POSITION □□R	CODE			
		1	2	4	8
10 STEP	0	●	●	●	●
	1	○	●	●	●
	2	●	○	●	●
	3	○	○	●	●
	4	●	●	○	●
	5	○	●	○	●
	6	●	○	○	●
	7	○	○	○	●
	8	●	●	●	○
	9	○	●	●	○
16 STEP	A	●	○	●	○
	B	○	○	●	○
	C	●	●	○	○
	D	○	●	○	○
	E	●	○	○	○
	F	○	○	○	○

CIRCUIT CHART

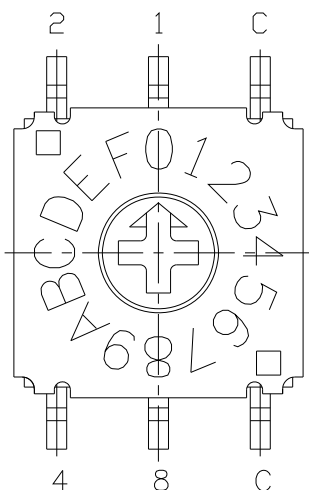

R7M3□-16R

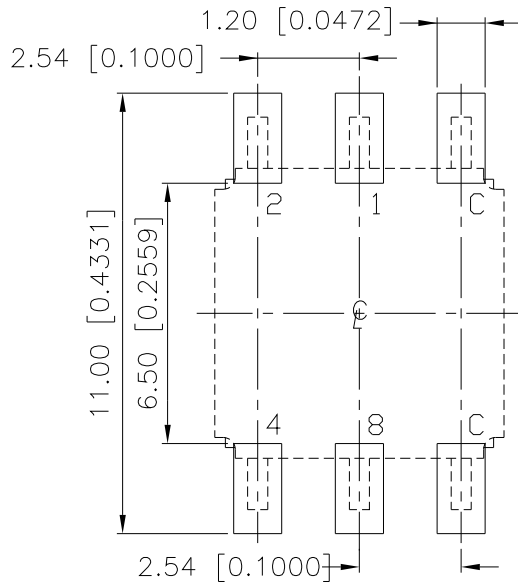

P.C.B. LAYOUT

NAME	L
R7M3-10RA-V	0
R7M3-16RA-V	0
R7M3H-10RA-V	3.00 [0.1181]
R7M3H-16RA-V	3.00 [0.1181]

General Tolerance : ±0.2mm

R7M3-RAG

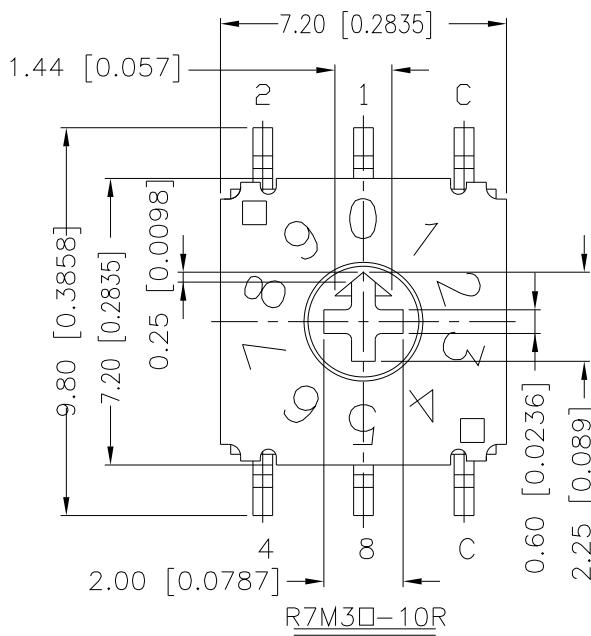

R7M3□-10R

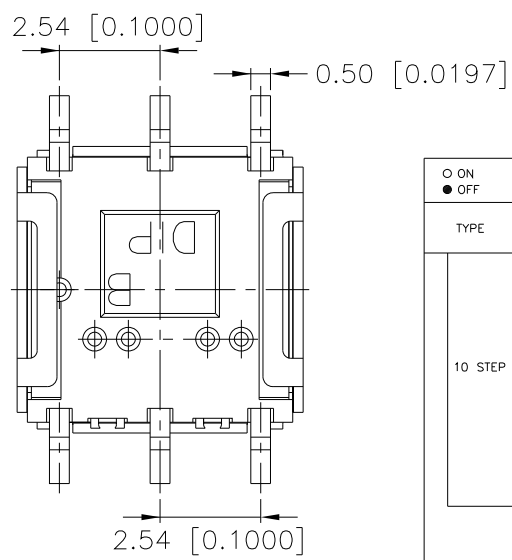
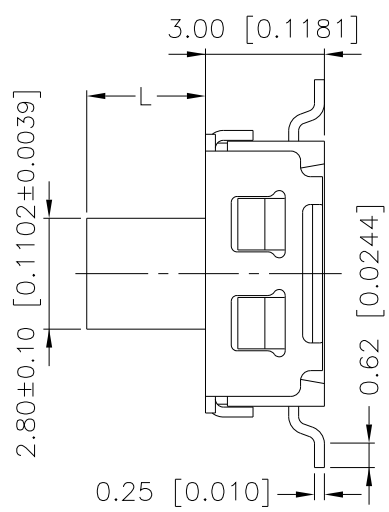

TYPE	POSITION □□R	CODE			
		1	2	4	8
10 STEP	0	●	●	●	●
	1	○	●	●	●
	2	●	○	●	●
	3	○	○	●	●
	4	●	●	○	●
	5	○	●	○	●
	6	●	○	○	●
	7	○	○	○	●
	8	○	●	●	○
	9	○	●	●	○
16 STEP	A	●	○	●	○
	B	○	○	●	○
	C	○	●	○	○
	D	○	●	○	○
	E	●	○	○	○
	F	○	○	○	○

CIRCUIT CHART

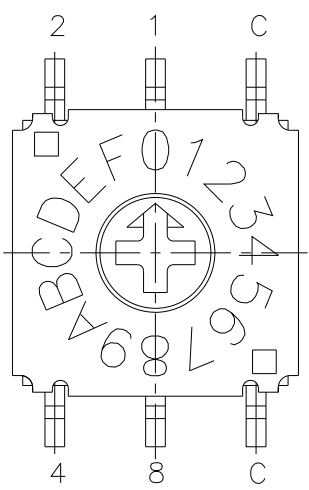

R7M3□-16R

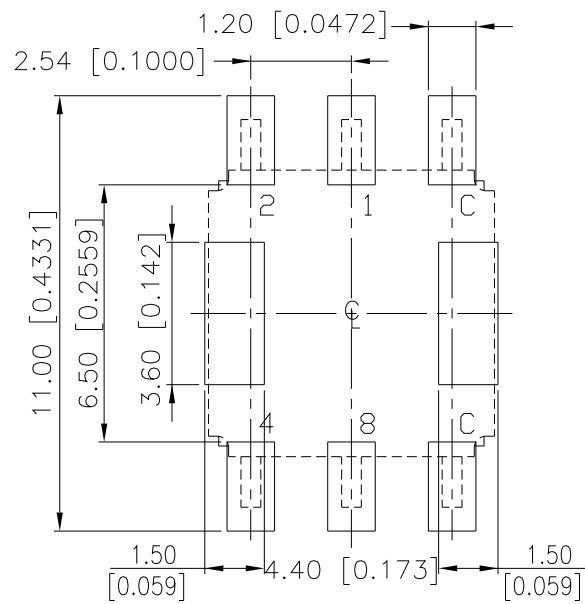

P.C.B. LAYOUT

NAME	L
R7M3-10RAG-V	0
R7M3-16RAG-V	0
R7M3H-10RAG-V	3.00 [0.1181]
R7M3H-16RAG-V	3.00 [0.1181]

General Tolerance : ±0.2mm

R7M4-RA

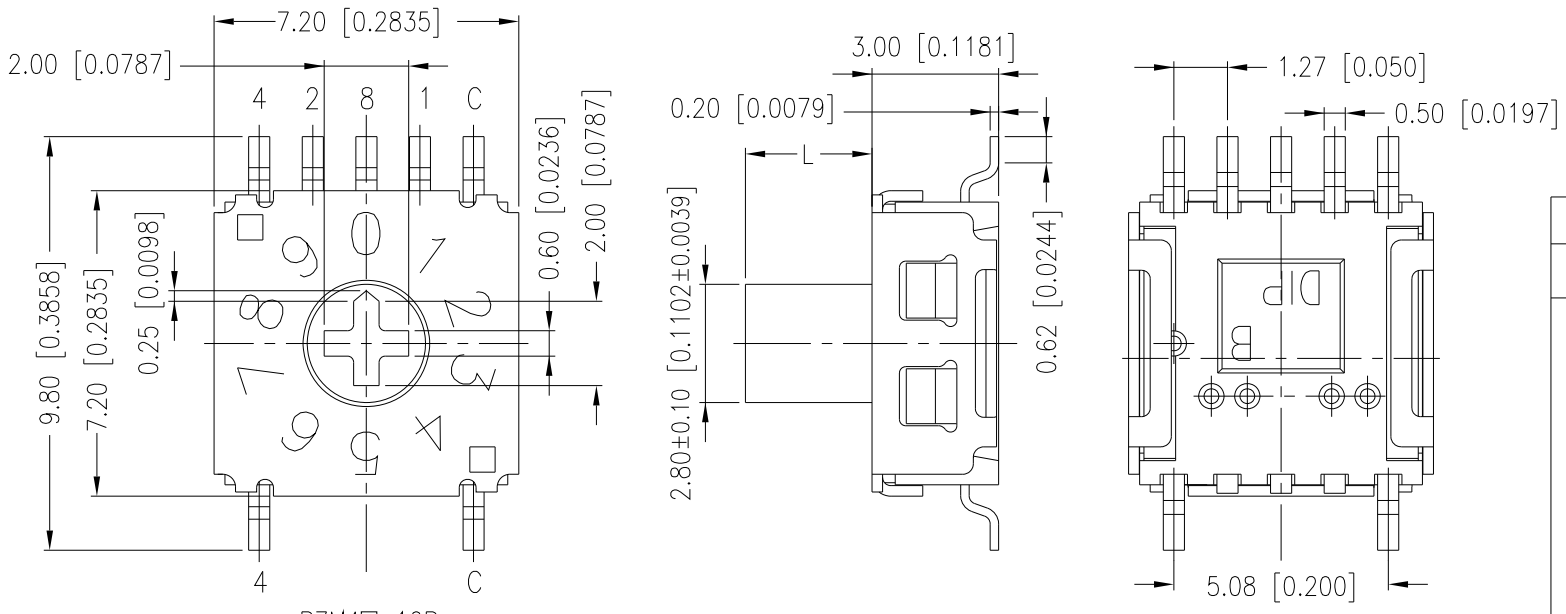

TYPE	POSITION □□R	CODE			
		1	2	4	8
10 STEP	0	●	●	●	●
	1	○	●	●	●
	2	●	○	●	●
	3	○	○	●	●
	4	●	●	○	●
	5	○	●	○	●
	6	●	○	○	●
	7	○	○	○	●
	8	○	○	●	○
16 STEP	9	○	●	●	○
	A	●	○	●	○
	B	○	○	●	○
	C	●	●	○	○
	D	○	●	○	○
	E	●	○	○	○
F	○	○	○	○	

CIRCUIT CHART

R7M4□-10R

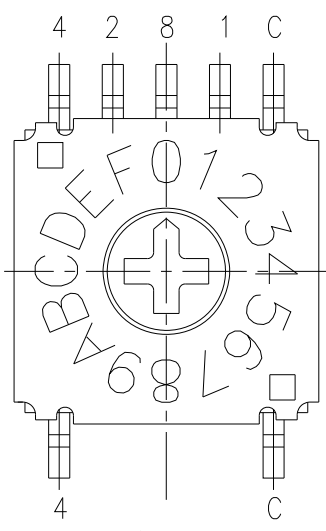

R7M4□-16R

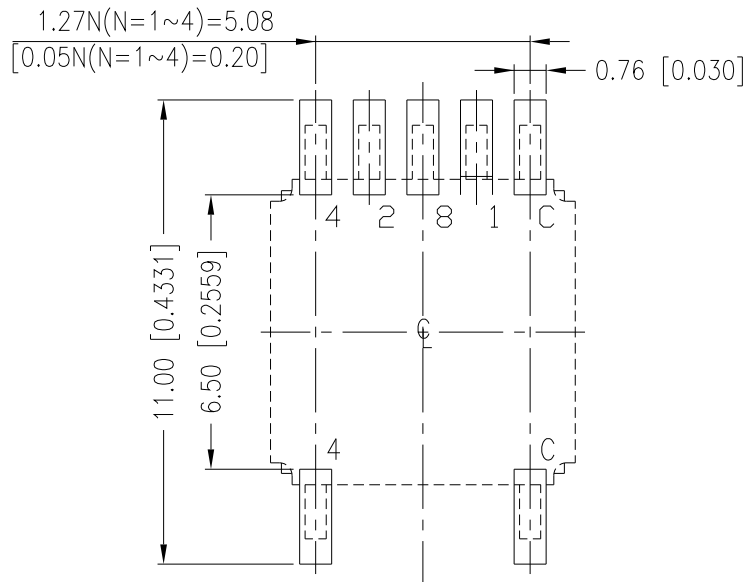

P.C.B. LAYOUT

NAME	L
R7M4-10RA-V	0
R7M4-16RA-V	0
R7M4H-10RA-V	3.00 [0.1181]
R7M4H-16RA-V	3.00 [0.1181]

General Tolerance : ±0.2mm

R7V3-RA

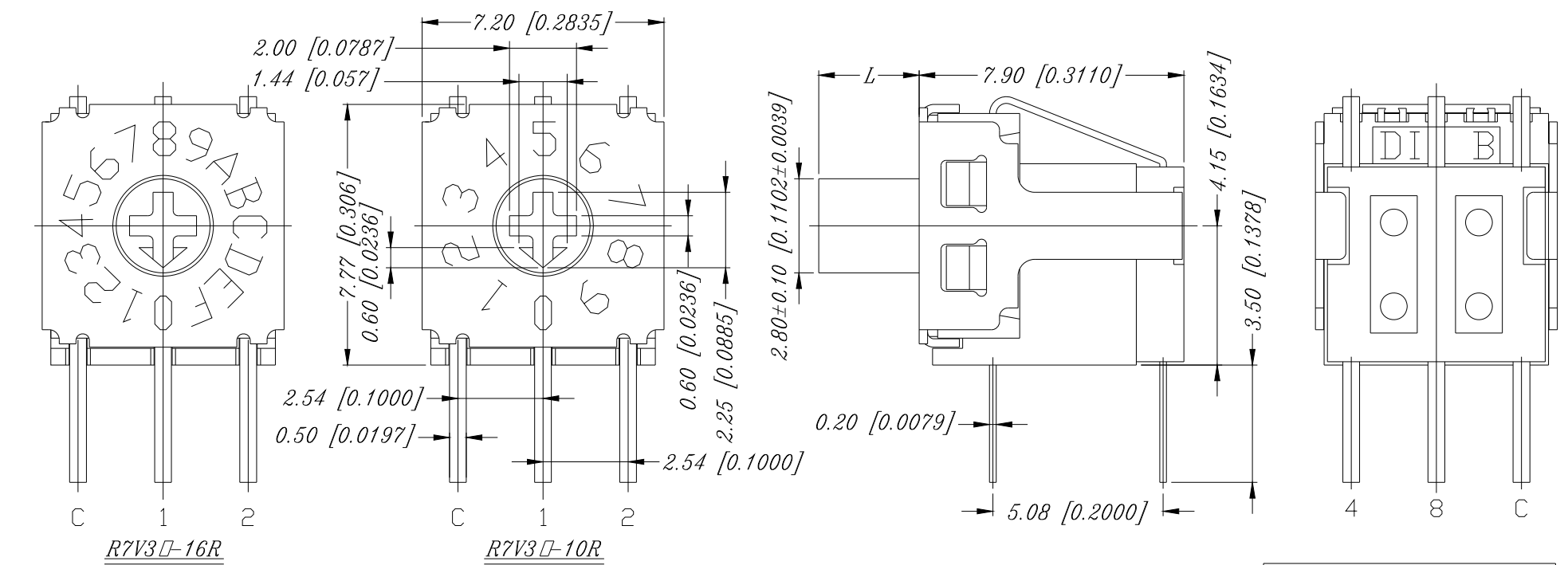

R7V3□-16R

R7V3□-10R

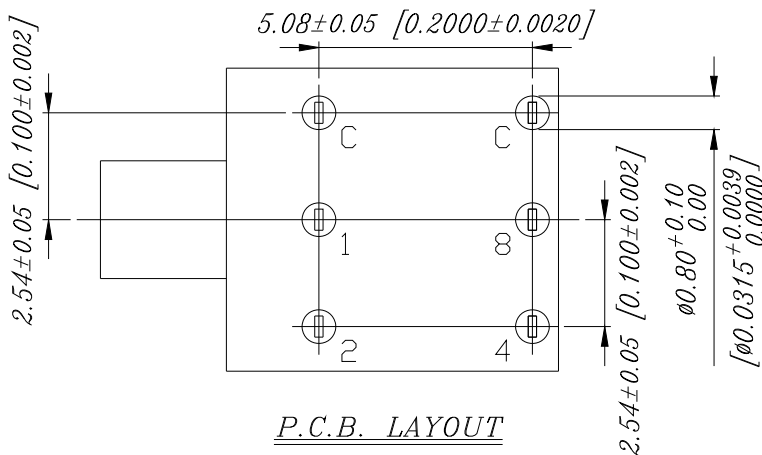

P.C.B. LAYOUT

NAME	L
R7V3-10RA-V	0
R7V3-16RA-V	0
R7V3H-10RA-V	3.00 [0.1181]
R7V3H-16RA-V	3.00 [0.1181]

TYPE	POSITION □□R	CODE			
		1	2	4	8
10 STEP	0	●	●	●	●
	1	○	●	●	●
	2	●	○	●	●
	3	○	○	●	●
	4	●	●	○	●
	5	○	●	○	●
	6	●	○	○	●
	7	○	○	○	●
	8	●	●	●	○
16 STEP	9	○	●	●	○
	A	●	○	●	○
	B	○	○	●	○
	C	●	●	○	○
	D	○	●	○	○
	E	●	○	○	○
F	○	○	○	○	

CIRCUIT CHART

General Tolerance : ±0.2mm

HOW TO ORDER

R 7 □ □ □ - □ □ R □ □ - □ - □

Package :

B = Tube

T/R = Tape & Reel

Soldering :

V =RoHS & Lead Free Solderable

Q =Halogen Free

□ = Without Ground Terminal

G = With Ground Terminal (S.M.T Only)

A = Cross-head Actuator

B = Flat-head Actuator

R = Real Codes.

Number Of Steps :

10 = 10 Steps

16 = 16 Steps

Actuator Type :

□ = Recessed Actuator

H = High Actuator (3.0mm)

Number Of Terminals :

3 = 3x3

4 = 4x1(To be available)

Termination Type :

M = S.M.T

H = Through Hole

V = Right Angle

A = S.M.T Right Angle(4x1 Only)

Rotary Type 7x7mm

SPECIFICATION

△MECHANICAL

Mechanical Life : 10,000 Steps
Operation Force : 200gf-cm max

△ENVIRONMENTAL

Operation Temperature Range : -30°C to +80°C
Storage Temperature Range : -40°C to +85°C

△ELECTRICAL

Electrical Life: 10,000 Steps
Switching Rating: 25 mA, 24 VDC

MATERIAL

△COVER : Nickel silver
△SEAL-1 : Silicone rubber
Color : Black, Square
△SEAL-2 : Silicone rubber
Color : Black, Round
△ACTUATOR : UL 94V-0 High-temp Thermoplastic
△BLOCK : Stainless steel
△CONTACT : Alloy copper
△SPRING PLATE : Piano wire
△BASE : UL 94V-0 High-temp Thermoplastic
Color : Black
△TERMINAL : Brass with gold plated

SOLDERING PROCESS

△HAND SOLDERING : Us a soldering iron of 30 watts, controlled at 350°C approximately 5 seconds while applying solder.

△REFLOW SOLDERING : When applying reflow soldering, the peak temperature or the reflow over should be set to 260°C max.

△Temperature Profile :

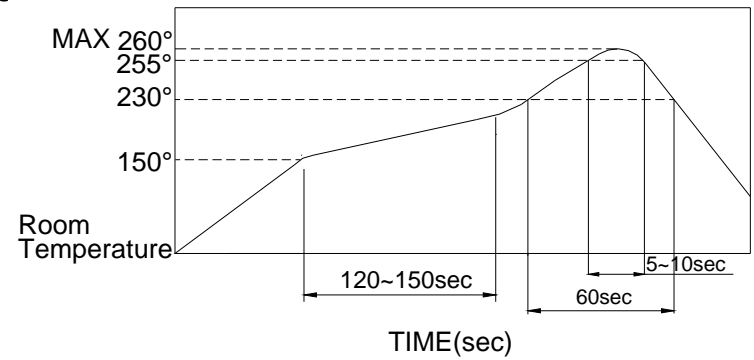

PACKING

Part Number	Number Per TUBE	Number Per REEL
R7M□	—	1450
R7M□H	—	850
R7A	—	750
R7A4H	—	750
R7V□	63	—
R7V□H	63	—
R7M□	65	—
R7M□H	65	—
R7H□	65	—
R4H□H	65	—

R7M□ REEL

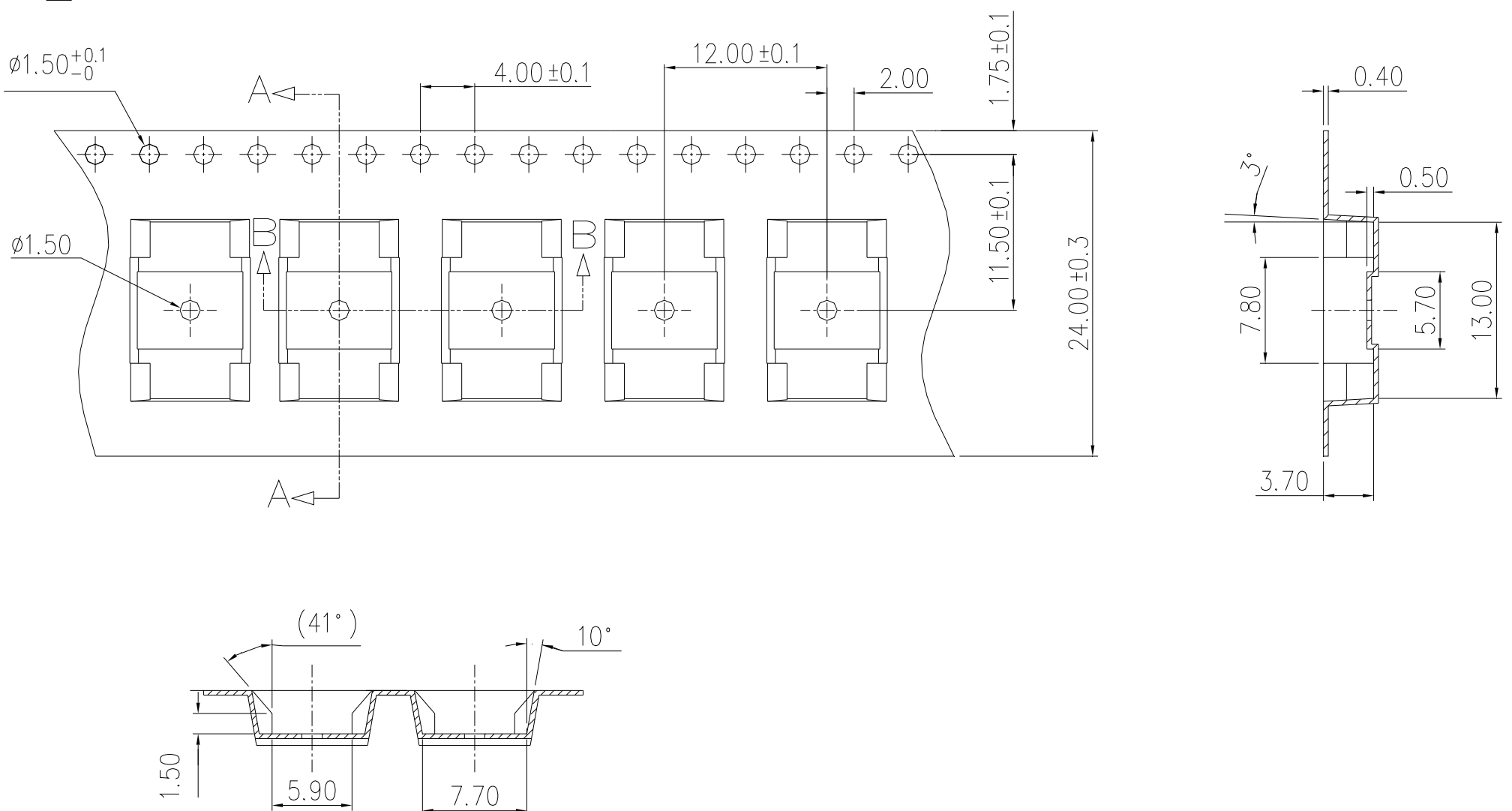

General Tolerance:±0.1mm

R7M□H REEL

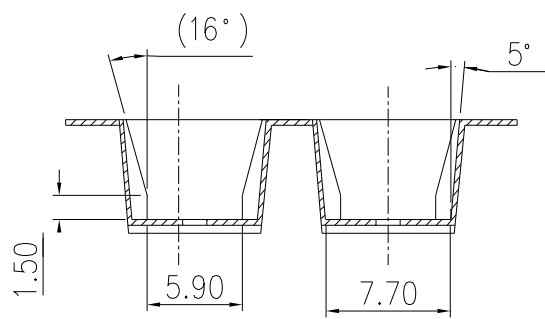
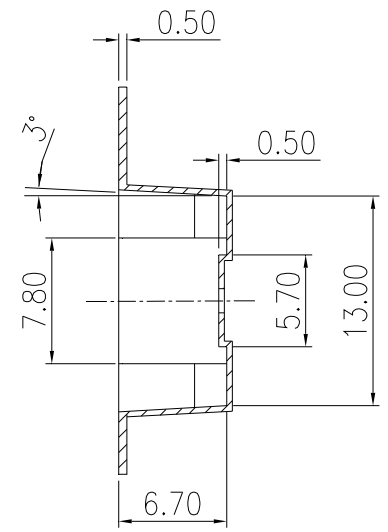
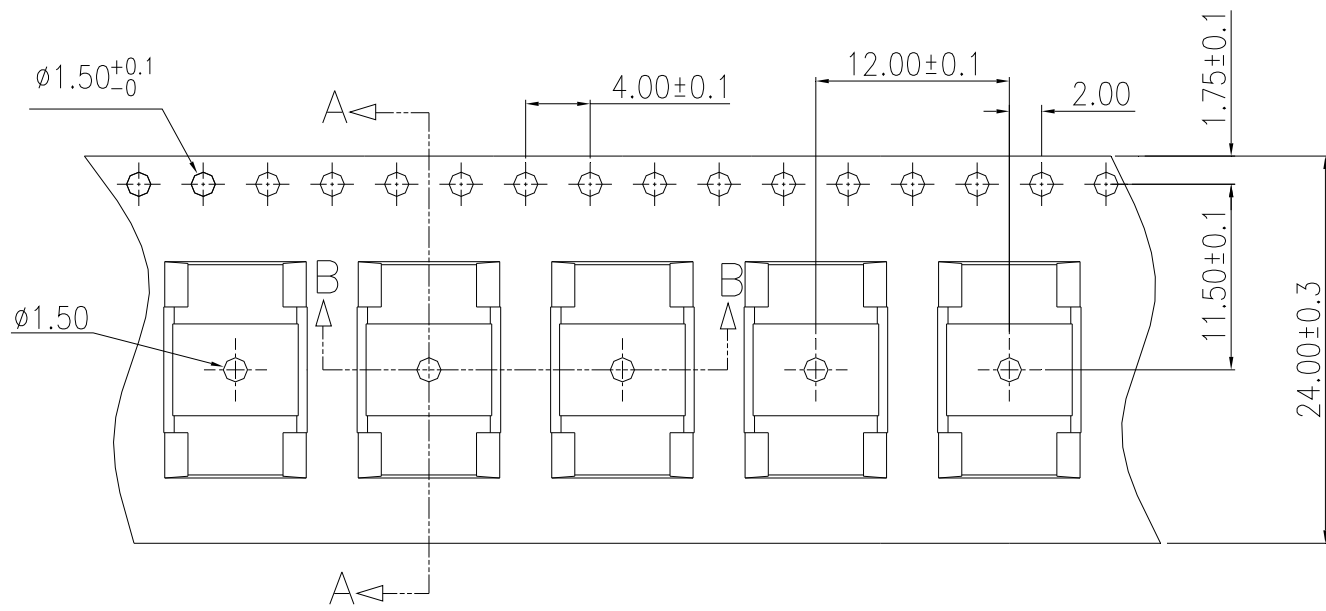

SECTION A-A

SECTION B-B

General Tolerance: ± 0.1 mm

R7V□ TUBE

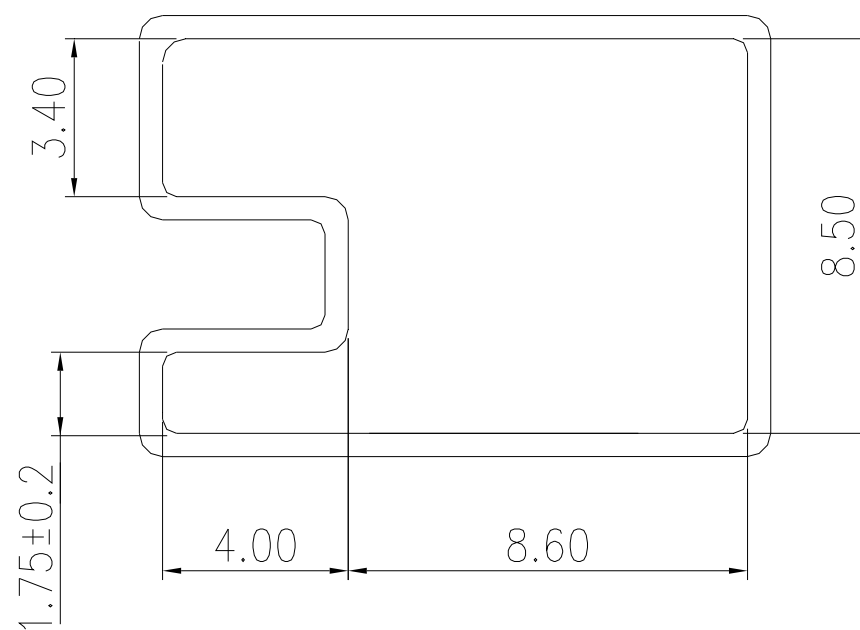

General Tolerance: ± 0.2 mm (± 0.008 ")

R7V □ H TUBE

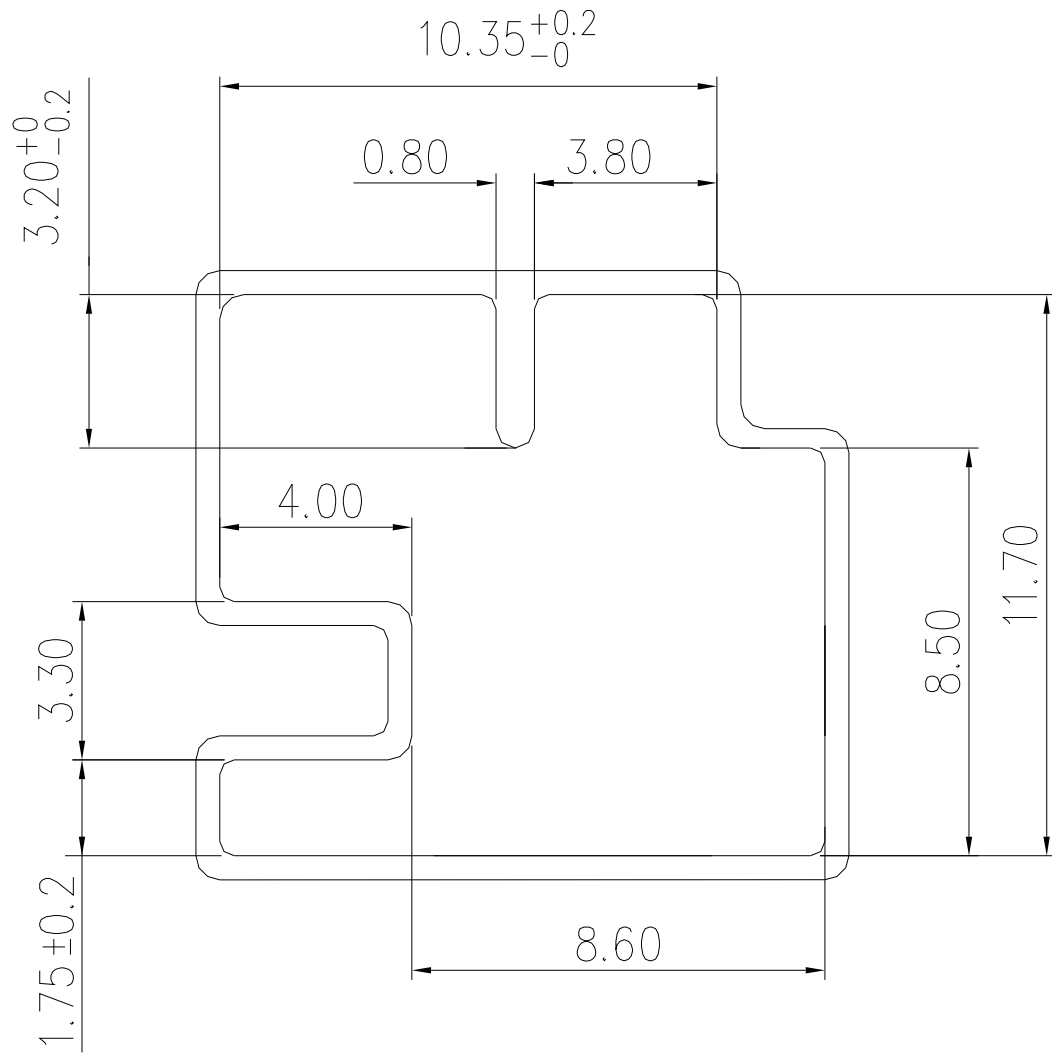

General Tolerance: $\pm 0.2\text{mm} (\pm 0.008\text{'})$

R7M □ TUBE

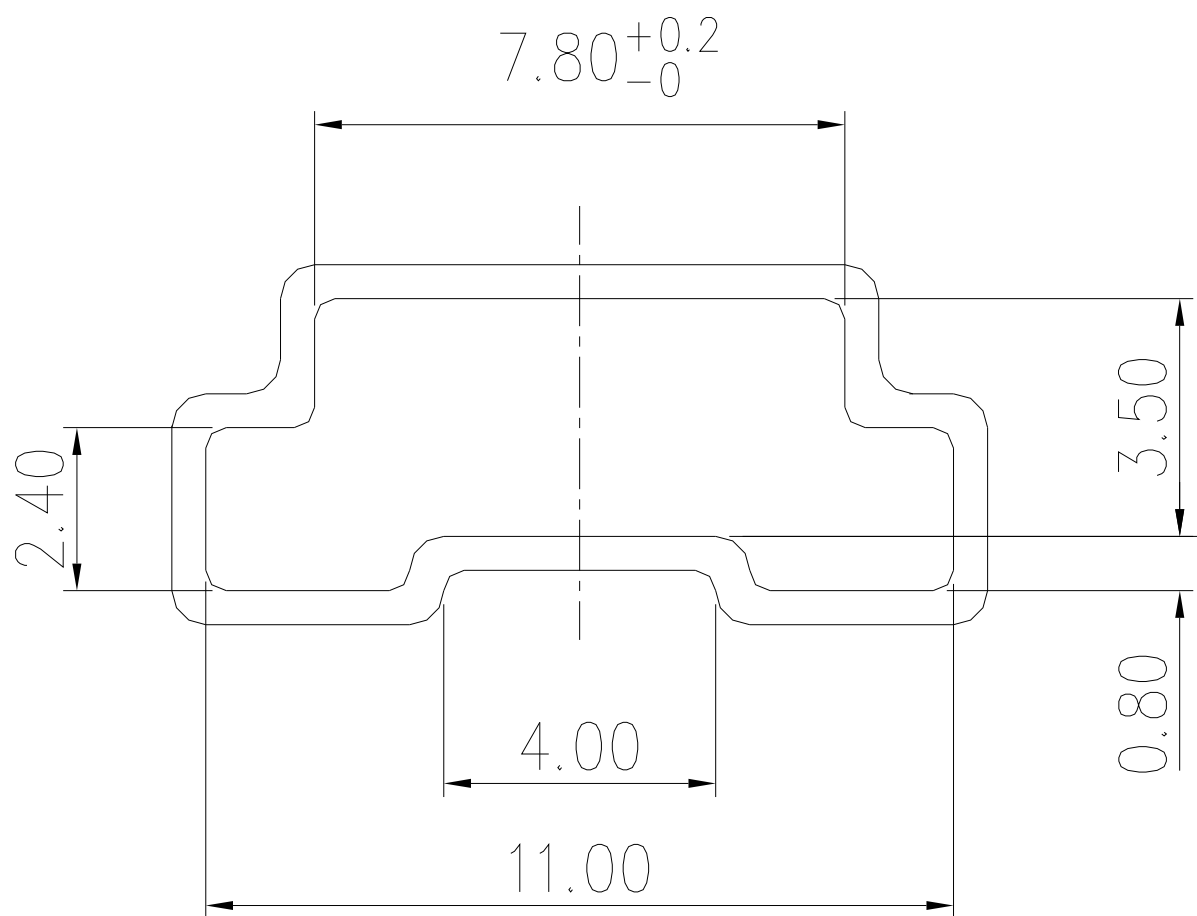

General Tolerance: $\pm 0.2\text{mm} (\pm 0.008\text{'})$

R7M□H TUBE

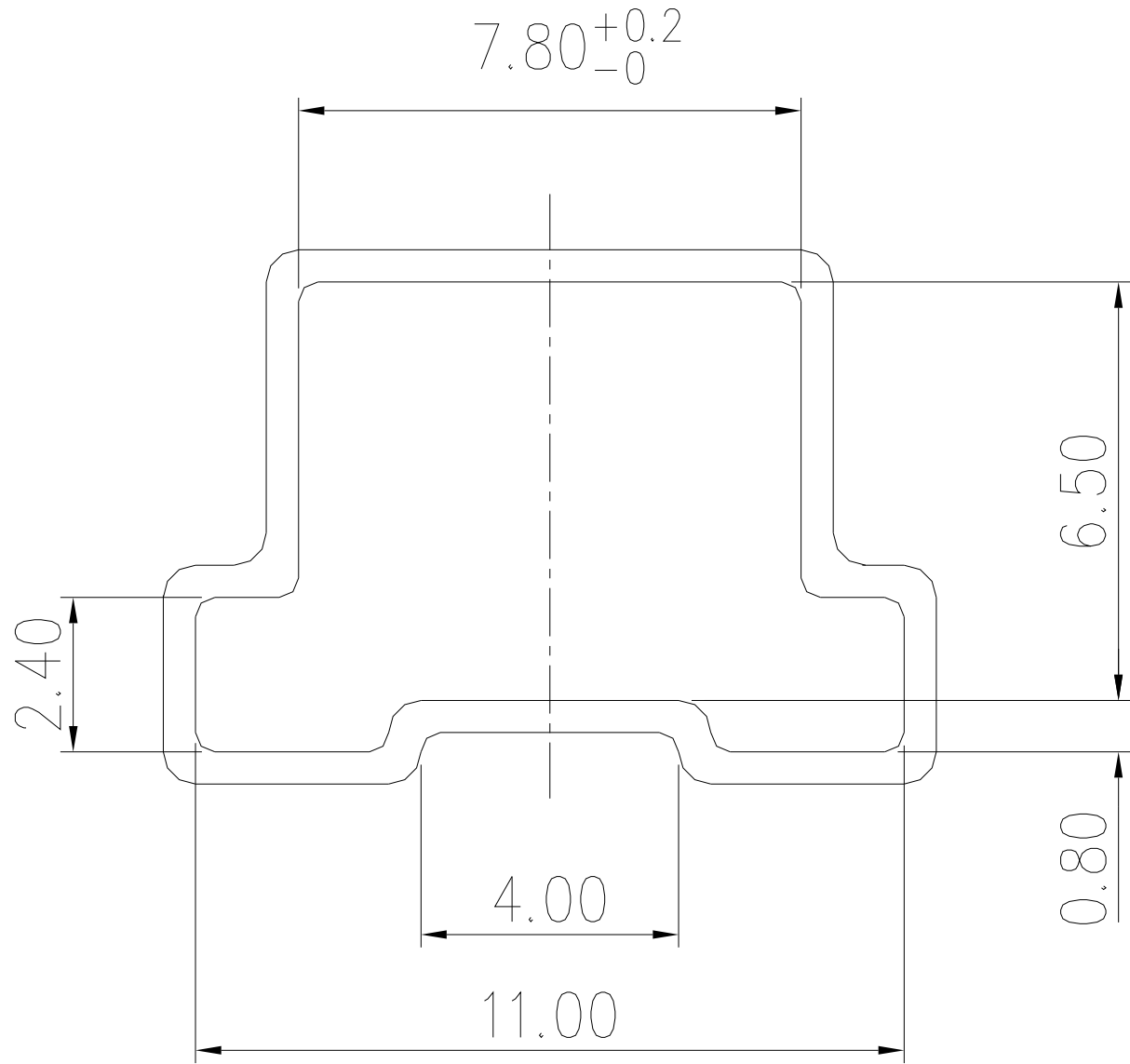

General Tolerance: ± 0.2 mm (± 0.008 ")

R7H□ TUBE

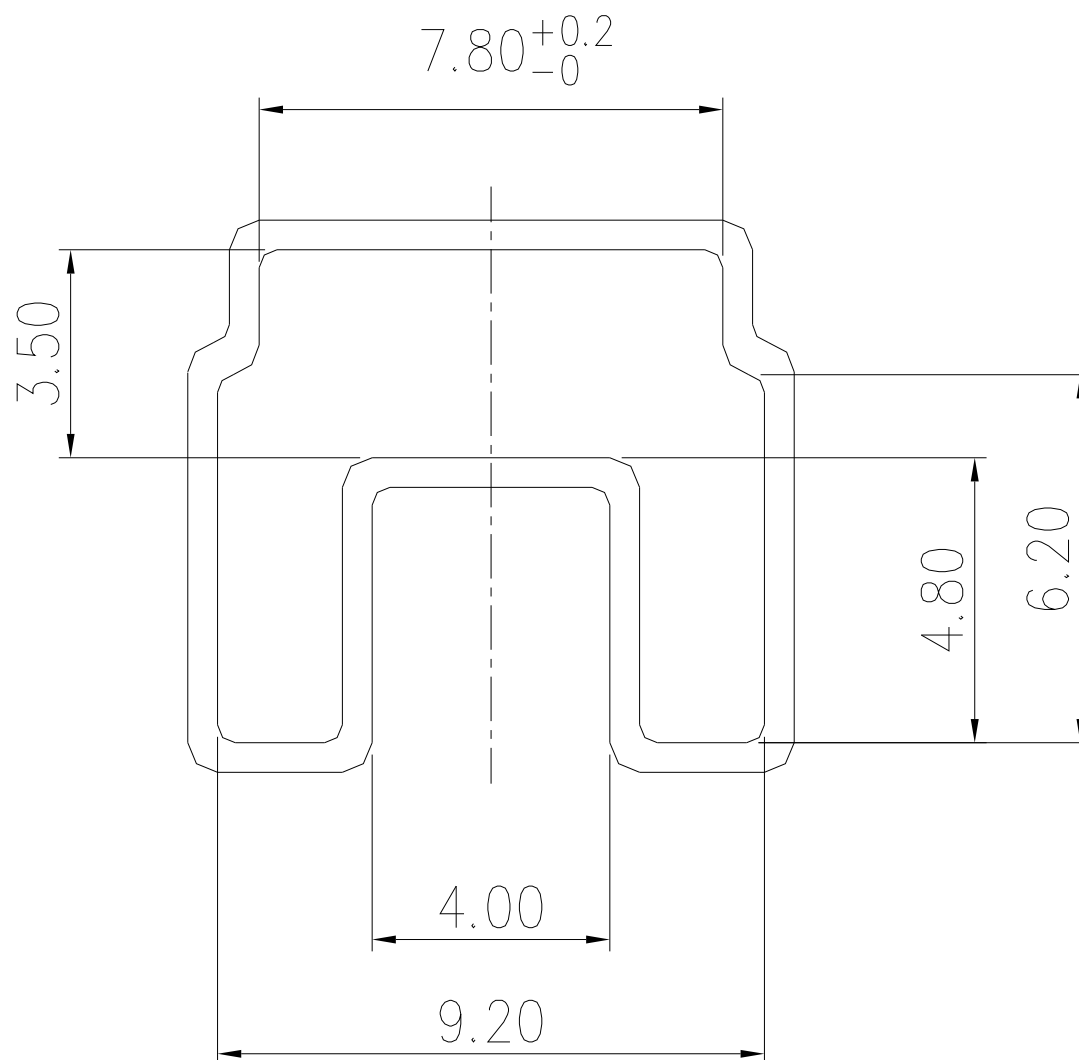

General Tolerance: ± 0.2 mm (± 0.008 ")

R7H□H TUBE

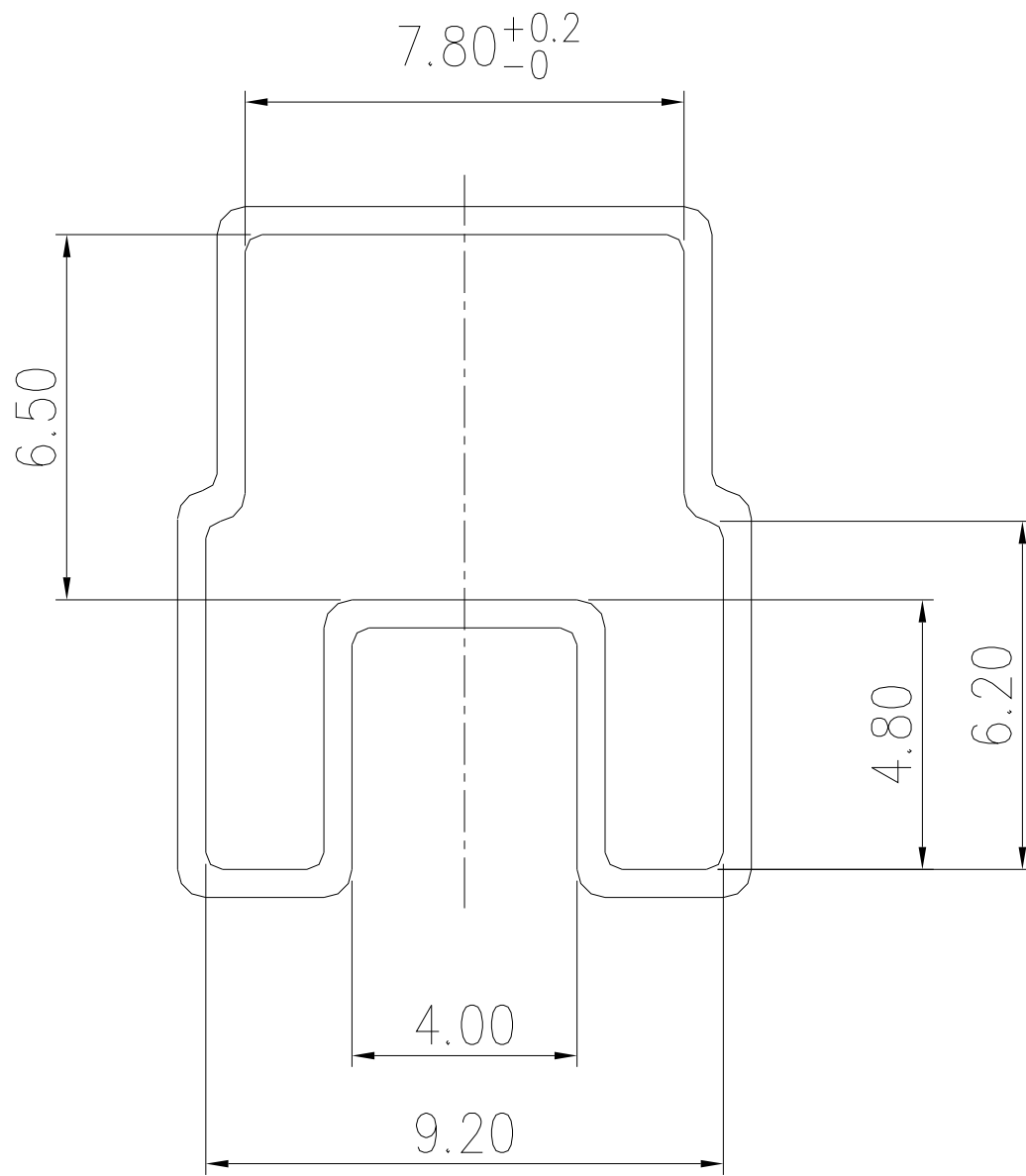

General Tolerance: $\pm 0.2\text{mm} (\pm 0.008")$